



 **schmidt**
a brand of aebi schmidt

Stratos Combi Soliq

Combination machine



The Stratos Combi Soliq is a highly versatile combination machine for winter maintenance under all weather conditions. It is extremely adaptable and offers a combination of different methods and spreading materials from one all-round machine. As such it is able to respond to a whole host of different weather conditions with the ideal solution to match the circumstances. These range from the spreading of abrasive materials, dry salt and wet salt with various brine percentages to brine spraying. Complete versatility in one all-rounder.

Highlights

- **Can be used for any winter service** and **in all weather conditions**
- Combination of **different methods** and **spreading materials**
- **Maximum volume utilisation**
- **Quick change** between **dry salt and brine**

Your benefits

- **Pre-wet 30 to pre-wet 100 applications** possible with a single device.
- **Uncomplicated operation** by one person within seconds - no modification necessary.
- **Rapid filling at up to 317 gal per minute** thanks to a large, three inch cross-section pipe.

Performance features

Different spreading methods

The Stratos Combi Soliq is suitable for a variety of spreading methods and can be used for all winter maintenance operations and in all weather conditions.

The most important de-icing agent is salt and there are various methods of applying it, which allows for differentiated de-icing. Possibly the most effective is wet salt spreading in which the salt is mixed with brine from appropriate tanks before it is applied. In this way, the salt adheres more quickly to the treated surface and develops a faster and longer lasting effect. As there are hardly any drifts, this method is very cost-effective and environmentally friendly.

International trials have shown that in certain situations, wet salt with a higher brine content, such as pre-wet 50 or pre-wet 70, can achieve greater effectiveness over longer periods of time with a lower quantity of salt. The key to this is the length of time that the salt lies on the road, depending on the road conditions, weather conditions, intensity of traffic and temperature.

Another highly efficient method is brine spraying in which brine, a salt/water solution, is sprayed directly onto the road surface. This results in a considerable reduction in salt usage and is especially designed for preventive de-icing.

Hopper and frame structure

The Stratos Combi Soliq hopper is available in two basic versions:

- **Normal hopper: 5.2-9.2 yd³ capacity**
- **Patented Flex hopper: 6.5 yd³ capacity**

Both versions can be equipped with additional, front-mounted brine tanks, plus a frame for support legs, hook loaders, fixed mounting or for RoRo.

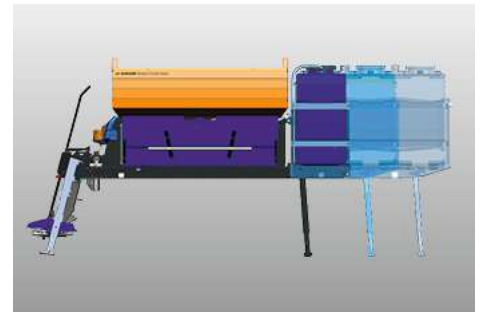

Flex hopper

Increased brine volume without refitting

The new, patented Flex hopper offers maximum adaptability. The brine volume can be increased without the need for change-overs, allowing for pre-wet 30, 50, 70 or 100 to be used from a single machine.

How it works

The Flex hopper contains two fixed high-strength plastic Flex bags which can be folded out as needed and filled with brine. They are filled via a C connection, with automatic filling of the side-mounted and front-mounted tanks and Flex bags. A large, three inch cross section pipe enables fast filling speeds of up to 317 gal per minute. The wet proportion of the mix can be changed easily on the control panel for optimised effectiveness with lower salt consumption. Two versions of the Flex hopper are available so that brine volumes can be increased from 343.4 or 739.7 to 660.4 or 1,162.4 gal.



Dosing and conveying systems

Belt conveyor system

The Stratos V-profile belt conveyor system delivers the uniform transport of spreading material. A stainless steel slide plate allows for minimum belt friction on the whole surface. The belt speed is adjusted automatically and, together with the dosing slide, allows for exact dosing. The dosing slide is equipped with an integrated lump crushing system that crushes lumps at a constant pressure, preventing the system becoming blocked or damaged. As a result, a uniform and constant feed allows for high dosing accuracy.

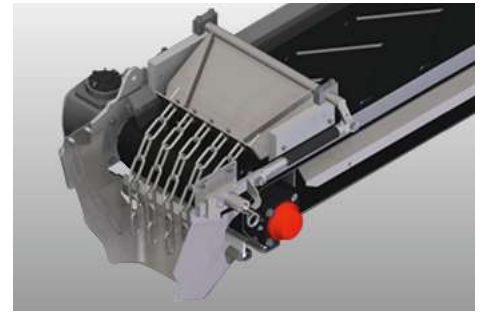

Auger conveyor system

The Stratos Flex auger conveyor with two-stage pitch is a cold-formed flat helix which allows for energy-efficient conveying with a low breakaway torque. The variable thread allows for uniform emptying of the hopper, ensuring the spreader maintains an even centre of gravity on the truck. The auger conveyor is powered by a high torque hydraulic motor for safe and stable starting. A constant target-actual comparison regulates the auger conveyor system at a precise and constant speed. A standard auger pressure relieve system relieves the auger from the pressure of the spreading materials and significantly increases the service life.

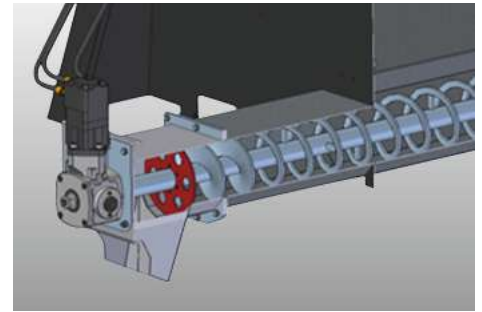

Brine device

The lateral and front-mounted liquid tanks, which have respective capacities of 488.7 gal and 581.2-660.4 gal, are made of impact and cold-resistant polyethylene with integrated baffles. The suction and ventilation points are located at the centre of the tank so that operation is possible in rough or mountainous terrain. An integrated filling level indicator allows for easy checking of the remaining brine volume, while the ergonomic, steel filling and emptying connector enables easy refilling at a rate of up to 317 gal per minute via a three inch cross section pipe. A hydraulically driven, high-performance brine pump with run-dry protection allows for constant feeding of brine, and an integrated revolution speed sensor ensures maximum accuracy.



The right de-icing agent at the touch of a button

The Stratos Combi Soliq can be equipped with a dual-liquid function. By using separate tanks and specially adapted control software, it is possible to carry two different de-icing fluids at the same time. This innovative function enables the driver to change the de-icing agent as required at the simple press of a button in the driver's cab. During a single journey, sections of road can be spread with FS 50 and sensitive areas such as bridges or uphill and downhill stretches can be sprayed with an alternative de-icing material. This flexibility contributes significantly to the Stratos Combi Soliq's cost-effectiveness.

Distribution systems

RSP distribution system

With the RSP variant, a combination of spreading and spraying is carried out via the spreading disc and, with a spraying width of up to 26.2 ft, is ideally suited for spraying on local roads. The distribution system can be raised by gas springs and is conveniently height-adjustable. A polyethylene discharging chute, together with the optimised angle of the outlet, allows for optimal material flow. A Premium spreading disc with a 19.3 in diameter is generally used. Optionally, however, a Premium spreading disc with a diameter of 660mm or a dual-layer spreading disc with a diameter of 27.6 in can be employed, both of which are suitable for spreading (pre-wet 30) and spraying (pre-wet 100).

RSP with dual-layer spreading disc

With the patented dual-layer 27.6 in spreading disc, varying widths can be sprayed. Widths of 9.8-26.2 ft (upper disc, pre-wet 100) or 9.8-32.8 ft (lower disc, pre-wet 30-70) can be sprayed as required. A new RSP plus option allows the spraying width to be increased to 29.5 ft by means of two jet nozzles.

WSP distribution system

With the WSP version, a combination of spreading and spraying is achieved via a Premium 26 in diameter spreading disc and a nozzle spray system with **in-house developed and patented nozzles**. The nozzle arms allow for a spraying width of up to three lanes or around 39.4 ft. Adjustment of width can be configured both as a lane or metre setting. During spraying, both dry salt and a wet salt mixture can be added, underlining that the Stratos Combi Soliq is a highly versatile and flexible piece of equipment.

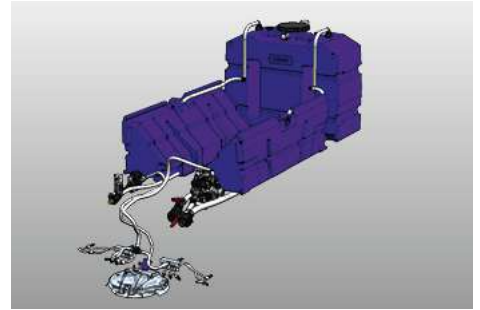
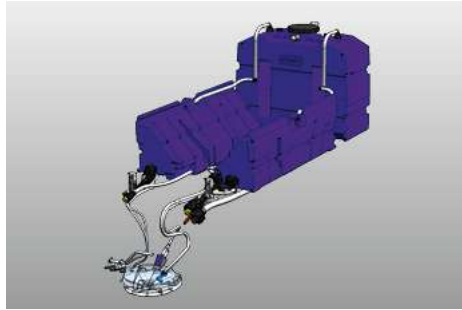
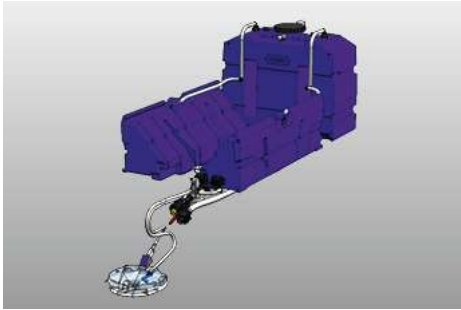

Municipal technology

In addition to winter use, the Stratos Combi Soliq can also be used in summer. The machine is used for washing, tunnel washing and street cleaning. With modifications to the control software and two additional taps for the four functions of filling, washing, spraying and servicing, the Stratos Combi Soliq becomes a „spreader“ that can be used all year round.

Drive, control and information systems

The Combi Soliq is operated clearly and easily using the highly efficient, fully road-speed related ES control panel, which features a frost-resistant 7" colour touch screen display housed in a splash-proof, robust casing. The click-turn knobs and illuminated push buttons ensure convenient operation of the primary and menu-dependent functions.



The systems can also be integrated with the latest smart technology:

- **ThermoLogic:** Temperature-dependent dosing
- **Route Assistant:** Automatic spreading with GPS navigation

Two operating concepts are available for controlling the Stratos Combi Soliq:

- **Percentage control:** The liquid share is always a percentage of the total sum
- **Dosage control:** In spray mode the liquid and solid share is given in g/m^2

IntelliOPS telematics platform

The Stratos Combi Soliq can be connected to the Aebi Schmidt IntelliOPS platform which provides comprehensive monitoring, selection, reporting and analysis functions. It enables rapid performance evaluation by displaying machine activity data live on a map and uses collected data to provide detailed overviews and reports to optimise operations.

Gallery



Variants

Stratos CS RSP 50 K Flex Low



The Stratos RSP 50K Flex High has a hopper volume of 6.5 yd³ with two integrated flex bags and is equipped with the RSP distribution system.

Stratos CS WSP 50K



The Stratos WSP 50K has a hopper volume of 6.5 yd³ and is equipped with the WSP distribution system.

Related product

Stratos 4.0 - 12.0 m³

Spreader



Tarron

Snowplow



Tarron HP-2W

Snowplow



Technical data

	Stratos CS RSP 40K	Stratos CS RSP 50K	Stratos CS RSP 50K Flex High
Hopper			
Hopper capacity	5.2 yd ³	6.5 yd ³	6.5 yd ³
Flex hopper	no	no	yes
Pre-wet equipment			
Tank capacity front tanks	3 x 581 gal	3 x 581 gal	3 x 660 gal
Tank capacity lateral tanks	488.7 gal	488.7 gal	488.7 gal
Tank capacity flex tank high	-	-	740 gal folded / 1,162 gal unfolded
Conveyor system			
Conveyor system	belt / auger	belt / auger	belt / auger
Distribution system			
Distribution systems	<p>RSP (CS spreading disc): Premium 5-zone Spreading disc diameter: 19.2 in Spreading width: 6.6 - 32.8 ft Spraying width: 6.6 - 19.7 ft</p> <p>RSP (CS spreading disc): Premium 5-zone Spreading disc diameter: 26 in Spreading width: 9.8 - 39.3 ft Spraying width: 9.8 - 26.2 ft</p> <p>RSP plus (CS spreading disc + spray nozzles): Premium 5-zone Spreading disc diameter: 26 in Spreading width: 9.8 - 39.3 ft Spraying width: 9.8 - 29.5 ft</p> <p>RSP plus (CS spreading disc + spray nozzles): Dual-Layer Spreading disc diameter: 27.6 in Spreading width: 9.8 - 39.3 ft Spraying width: FS 30 - FS 70: 9.8 - 32.8 FS 100: 9.8 - 29.5 ft</p> <p>RSP (CS spreading disc): Dual-Layer Spreading disc diameter: 27.6 in Spreading width: 9.8 - 39.3 ft Spraying width: FS 30 - FS 70: 9.8 - 32.8 FS 100: 9.8 - 26.2 ft</p>	<p>RSP (CS spreading disc): Premium 5-zone Spreading disc diameter: 19.2 in Spreading width: 6.6 - 32.8 ft Spraying width: 6.6 - 19.7 ft</p> <p>RSP (CS spreading disc): Premium 5-zone Spreading disc diameter: 26 in Spreading width: 9.8 - 39.3 ft Spraying width: 9.8 - 26.2 ft</p> <p>RSP plus (CS spreading disc + spray nozzles): Premium 5-zone Spreading disc diameter: 26 in Spreading width: 9.8 - 39.3 ft Spraying width: 9.8 - 29.5 ft</p> <p>RSP (CS spreading disc): Dual-Layer Spreading disc diameter: 27.6 in Spreading width: 9.8 - 39.3 ft Spraying width: FS 30 - FS 70: 9.8 - 32.8 FS 100: 9.8 - 26.2 ft</p> <p>RSP plus (CS spreading disc + spray nozzles): Dual-Layer Spreading disc diameter: 27.6 in Spreading width: 9.8 - 39.3 ft Spraying width: FS 30 - FS 70: 9.8 - 32.8 FS 100: 9.8 - 29.5 ft</p>	<p>RSP (CS spreading disc): Premium 5-zone Spreading disc diameter: 19.2 in Spreading width: 6.6 - 32.8 ft Spraying width: 6.6 - 19.7 ft</p> <p>RSP (CS spreading disc): Premium 5-zone Spreading disc diameter: 26 in Spreading width: 9.8 - 39.3 ft Spraying width: 9.8 - 26.2 ft</p> <p>RSP plus (CS spreading disc + spray nozzles): Dual-Layer Spreading disc diameter: 27.6 in Spreading width: 9.8 - 39.3 ft Spraying width: FS 30 - FS 70: 9.8 - 32.8 FS 100: 9.8 - 26.2 ft</p> <p>RSP plus (CS spreading disc + spray nozzles): Premium 5-zone Spreading disc diameter: 26 in Spreading width: 9.8 - 39.3 ft Spraying width: 9.8 - 29.5 ft</p> <p>RSP plus (CS spreading disc + spray nozzles): Dual-Layer Spreading disc diameter: 27.6 in Spreading width: 9.8 - 39.3 ft Spraying width: FS 30 - FS 70: 9.8 - 32.8 FS 100: 9.8 - 29.5 ft</p>
Mounting/demount system			
Mounting/demount system	RoRo / Demount legs / Hoofklift / Fixed-mounted	RoRo / Demount legs / Hoofklift / Fixed-mounted	RoRo / Demount legs / Hoofklift / Fixed-mounted
Drive system			
Type of drive	Vehicle hydraulics	Vehicle hydraulics	Vehicle hydraulics
Control system			
Control system	ES	ES	ES
	Stratos CS RSP 50 K Flex Low	Stratos CS RSP 60K	Stratos CS RSP 70K
Hopper			
Hopper capacity	6.5 yd ³	7.9 yd ³	9.2 yd ³
Flex hopper	yes	no	no
Pre-wet equipment			
Tank capacity front tanks	3 x 581 gal	3 x 660 gal	3 x 660 gal
Tank capacity lateral tanks	488.7 gal	488.7 gal	488.7 gal
Tank capacity flex tank low	343 gal folded / 660 gal unfolded	-	-
Conveyor system			
Conveyor system	belt / auger	belt / auger	belt / auger
Distribution system			

	Stratos CS RSP 50 K Flex Low	Stratos CS RSP 60K	Stratos CS RSP 70K
Distribution systems	<p>RSP (CS spreading disc): Premium 5-zone Spreading disc diameter: 19.2 in Spreading width: 6.6 - 32.8 ft Spraying width: 6.6 - 19.7 ft</p> <p>RSP (CS spreading disc): Premium 5-zone Spreading disc diameter: 26 in Spreading width: 9.8 - 39.3 ft Spraying width: 9.8 - 26.2 ft</p> <p>RSP (CS spreading disc): Dual-Layer Spreading disc diameter: 27.6 in Spreading width: 9.8 - 39.3 ft Spraying width: FS 30 - FS 70: 9.8 - 32.8 FS 100: 9.8 - 26.2 ft</p> <p>RSP plus (CS spreading disc + spray nozzles): Premium 5-zone Spreading disc diameter: 26 in Spreading width: 9.8 - 39.3 ft Spraying width: 9.8 - 29.5 ft</p> <p>RSP plus (CS spreading disc + spray nozzles): Dual-Layer Spreading disc diameter: 27.6 in Spreading width: 9.8 - 39.3 ft Spraying width: FS 30 - FS 70: 9.8 - 32.8 FS 100: 9.8 - 29.5 ft</p>	<p>RSP (CS spreading disc): Premium 5-zone Spreading disc diameter: 19.2 in Spreading width: 6.6 - 32.8 ft Spraying width: 6.6 - 19.7 ft</p> <p>RSP (CS spreading disc): Premium 5-zone Spreading disc diameter: 26 in Spreading width: 9.8 - 39.3 ft Spraying width: 9.8 - 26.2 ft</p> <p>RSP (CS spreading disc): Dual-Layer Spreading disc diameter: 27.6 in Spreading width: 9.8 - 39.3 ft Spraying width: FS 30 - FS 70: 9.8 - 32.8 FS 100: 9.8 - 26.2 ft</p> <p>RSP plus (CS spreading disc + spray nozzles): Premium 5-zone Spreading disc diameter: 26 in Spreading width: 9.8 - 39.3 ft Spraying width: 9.8 - 29.5 ft</p> <p>RSP plus (CS spreading disc + spray nozzles): Dual-Layer Spreading disc diameter: 27.6 in Spreading width: 9.8 - 39.3 ft Spraying width: FS 30 - FS 70: 9.8 - 32.8 FS 100: 9.8 - 29.5 ft</p>	<p>RSP (CS spreading disc): Premium 5-zone Spreading disc diameter: 19.2 in Spreading width: 6.6 - 32.8 ft Spraying width: 6.6 - 19.7 ft</p> <p>RSP (CS spreading disc): Premium 5-zone Spreading disc diameter: 26 in Spreading width: 9.8 - 39.3 ft Spraying width: 9.8 - 26.2 ft</p> <p>RSP (CS spreading disc): Dual-Layer Spreading disc diameter: 27.6 in Spreading width: 9.8 - 39.3 ft Spraying width: FS 30 - FS 70: 9.8 - 32.8 FS 100: 9.8 - 26.2 ft</p> <p>RSP plus (CS spreading disc + spray nozzles): Premium 5-zone Spreading disc diameter: 26 in Spreading width: 9.8 - 39.3 ft Spraying width: 9.8 - 29.5 ft</p> <p>RSP plus (CS spreading disc + spray nozzles): Dual-Layer Spreading disc diameter: 27.6 in Spreading width: 9.8 - 39.3 ft Spraying width: FS 30 - FS 70: 9.8 - 32.8 FS 100: 9.8 - 29.5 ft</p>
Mounting/demount system			
Mounting/demount system	RoRo / Demount legs / Hoofklift / Fixed-mounted	RoRo / Demount legs / Hoofklift / Fixed-mounted	RoRo / Demount legs / Hoofklift / Fixed-mounted
Drive system			
Type of drive	Vehicle hydraulics	Vehicle hydraulics	Vehicle hydraulics
Control system			
Control system	ES	ES	ES
	Stratos CS WSP 40K	Stratos CS WSP 50K	Stratos CS WSP 50K Flex High
Hopper			
Hopper capacity	5.2 yd ³	6.5 yd ³	6.5 yd ³
Flex hopper	no	no	yes
Pre-wet equipment			
Tank capacity front tanks	3 x 581 gal	3 x 581 gal	3 x 660 gal
Tank capacity lateral tanks	488.7 gal	488.7 gal	488.7 gal
Tank capacity flex tank high	-	-	740 gal folded / 1,162 gal unfolded
Conveyor system			
Conveyor system	belt / auger	belt / auger	belt / auger
Distribution system			
Distribution systems	<p>WSP (CS spreading disc + spray nozzle arms): Premium 5-zone Spreading disc diameter: 23.6 in Spreading width: 9,8 - 39,3 ft Spraying width: 9.8 - 35.4 ft</p> <p>WSP (CS spreading disc + spray nozzle arms): Premium 5-zone Spreading disc diameter: 23.6 in Spreading width: 9,8 - 39,3 ft Spraying width: 13.1 - 39.3 ft</p>	<p>WSP (CS spreading disc + spray nozzle arms): Premium 5-zone Spreading disc diameter: 23.6 in Spreading width: 9,8 - 39,3 ft Spraying width: 9.8 - 35.4 ft</p> <p>WSP (CS spreading disc + spray nozzle arms): Premium 5-zone Spreading disc diameter: 23.6 in Spreading width: 9,8 - 39,3 ft Spraying width: 13.1 - 39.3 ft</p>	<p>WSP (CS spreading disc + spray nozzle arms): Premium 5-zone Spreading disc diameter: 23.6 in Spreading width: 9,8 - 39,3 ft Spraying width: 9.8 - 35.4 ft</p> <p>WSP (CS spreading disc + spray nozzle arms): Premium 5-zone Spreading disc diameter: 23.6 in Spreading width: 9,8 - 39,3 ft Spraying width: 13.1 - 39.3 ft</p>
Mounting/demount system			
Mounting/demount system	RoRo / Demount legs / Hoofklift / Fixed-mounted	RoRo / Demount legs / Hoofklift / Fixed-mounted	RoRo / Demount legs / Hoofklift / Fixed-mounted
Drive system			
Type of drive	Vehicle hydraulics	Vehicle hydraulics	Vehicle hydraulics
Control system			

	Stratos CS WSP 40K	Stratos CS WSP 50K	Stratos CS WSP 50K Flex High
Control system	ES	ES	ES
	Stratos CS WSP 50K Flex Low	Stratos CS WSP 60K	Stratos CS WSP 70K
Hopper			
Hopper capacity	6.5 yd ³	7.9 yd ³	9.2 yd ³
Flex hopper	yes	no	no
Pre-wet equipment			
Tank capacity front tanks	3 x 581 gal	3 x 660 gal	3 x 660 gal
Tank capacity lateral tanks	488.7 gal	488.7 gal	488.7 gal
Tank capacity flex tank low	343 gal folded / 660 gal unfolded	-	-
Conveyor system			
Conveyor system	belt / auger	belt / auger	belt / auger
Distribution system			
Distribution systems	WSP (CS spreading disc + spray nozzle arms): Premium 5-zone Spreading disc diameter: 23.6 in Spreading width: 9,8 - 39,3 ft Spraying width: 9.8 - 35.4 ft WSP (CS spreading disc + spray nozzle arms): Premium 5-zone Spreading disc diameter: 23.6 in Spreading width: 9,8 - 39,3 ft Spraying width: 13.1 - 39.3 ft	WSP (CS spreading disc + spray nozzle arms): Premium 5-zone Spreading disc diameter: 23.6 in Spreading width: 9,8 - 39,3 ft Spraying width: 9.8 - 35.4 ft WSP (CS spreading disc + spray nozzle arms): Premium 5-zone Spreading disc diameter: 23.6 in Spreading width: 9,8 - 39,3 ft Spraying width: 13.1 - 39.3 ft	WSP (CS spreading disc + spray nozzle arms): Premium 5-zone Spreading disc diameter: 23.6 in Spreading width: 9,8 - 39,3 ft Spraying width: 9.8 - 35.4 ft WSP (CS spreading disc + spray nozzle arms): Premium 5-zone Spreading disc diameter: 23.6 in Spreading width: 9,8 - 39,3 ft Spraying width: 13.1 - 39.3 ft
Mounting/demount system			
Mounting/demount system	RoRo / Demount legs / Hoofklift / Fixed-mounted	RoRo / Demount legs / Hoofklift / Fixed-mounted	RoRo / Demount legs / Hoofklift / Fixed-mounted
Drive system			
Type of drive	Vehicle hydraulics	Vehicle hydraulics	Vehicle hydraulics
Control system			
Control system	ES	ES	ES



© Aebi Schmidt Group
www.aebi-schmidt.com

Aebi Schmidt North America Inc.
Chilton, WI 53014, USA

All rights reserved. Technical data is subject to change.
Illustrations are not binding. Errors and amendments excepted.

Document created on 11 FEB 2024

